



Capsule Band-Sealing Machine



Capsule Band-Sealing Machine

S2

Features

- Prevents the leakage of liquid fills.
- Reduces the oxidation of the capsule contents.
- Demonstrates tamper evidence.
- Newly designed top plate makes it easy to work inside the machine.
- Easy cleaning of top plate and chain assembly by lifting the machine's lid.
- Exterior sensors replaced with smaller interior sensors.
- New in-line plate positioning creates a higher capacity with better and faster sealing.
- Newly simplified control panel.
- Now featuring better air ventilation.

Mechanism

EMERGENCY STOP Switch

- This two-position switch controls the motor's power and heater.

RUN Switch

- Starts the capsule slat drive motor.

ON-OFF Switch, Heater

- Starts and stops the heater. When the pilot light is on, the heater is powered on.

ON-OFF Switch, Banding Wheel

- Starts and stops the motor wheel. When the pilot light is on, the heater is powered on.

Temperature Control and Indicator

- When the gelatin pan is properly in position, the temperature controller will display the heat transfer fluid temperature. The controller is front-panel-adjustable from 0-500 degrees Fahrenheit.

Interlock, Tabletop Safety

- If the table is not down and in its proper operating position, the interlock prevents the operation of the slat drive chain.

Interlock, Gelatin Pan Heater Safety

- The interlock on the gelatin pan turns off power to the gelatin pan heating element if the gelatin pan is not raised into proper operating position.

Capsule Band-Sealing Machine

S2



Mechanism cont'd

Interlock, Removable Panel Safety

- The interlock on the front panel stops the operation of the slat drive chain if the front panel is not in the proper operating position.

Chain Speed Potentiometer

- The chain speed potentiometer controls the speed, up or down, of the chain motor.

Wheel Speed Potentiometer

- The banding wheel potentiometer controls the speed, up or down, of the sealer motor.

Two Points of Adjustment

1. The first point of adjustment is vertical, which determines how much of the banding wheels will protrude through the tabletop. The amount of wheel protruding through the tabletop will determine the amount of banding solution that will be transferred to the capsule.
2. The second point of adjustment is horizontal, which determines the position of the brand, with respect to the cap/body joint line.

Banding Wheel Assembly

- The banding wheels transfer gelatin from the gelatin pan to the circumference of the hard gelatin capsules
 - a) Wheels are a matched set, as shown by their marking on the respective parts and must not be interchanged.
 - b) Wheels are to be assembled and installed so that the identification markings on the banding wheels face the front of the machine.

Capsule Band-Sealing Machine

S2

Specification

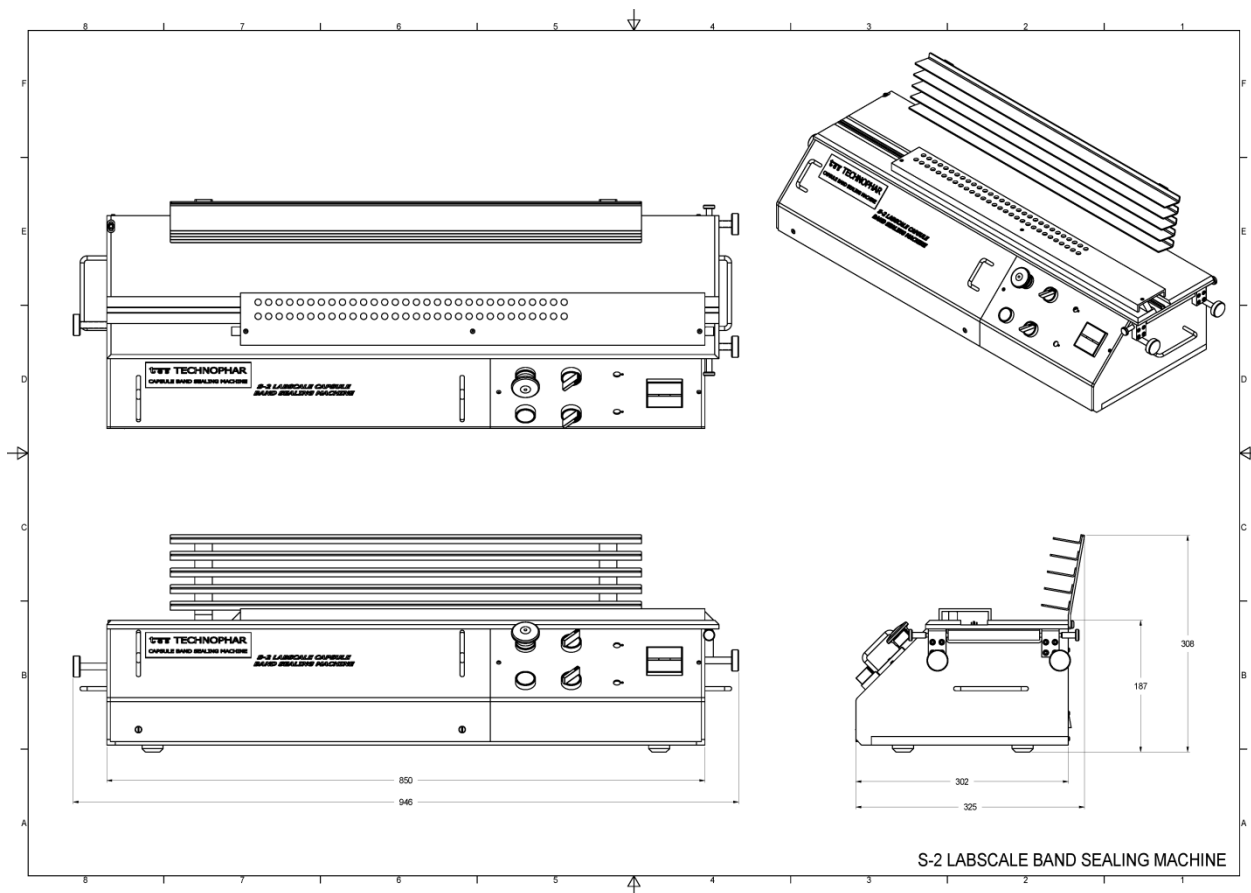

S-2 LABSCALE BAND SEALING MACHINE

S2	
Dimensions (mm)	736.6 W X 304.8 D X 304.8 H
Weight (kg)	29.45
Machine Electrical Power	230 V AC, 50/60 Hz, 4 Amps

TECHNOPHAR

Technophar Global Headquarters
 3293 St. Etienne Blvd.
 Windsor, Ontario, Canada N8W 5B1
 Phone: +1 519-946-0800
www.technophar.com