

technophar
A QUALICAPS COMPANY

Commercial Scale Soft Gel Machine

SGM407NextGen®



Commercial Scale Soft Gel Machine

SGM407NextGen®

The **SGM407NextGen®** Commercial Scale Soft Gel Machine is highly efficient, meets cGMP requirements and can produce accuracy for large-scale production. It offers PLC with touchscreen for improved control of processes. Electrical components and PLC located in separate electrical panel which can be placed in production room or technical mezzanine via flexible electrical conduit.

Features

- **Motion Control System:** the mechanical gearing replaced with electronic gearing (implemented with closed loop control systems) using servo motors.
- **Die Roll Dimensions:** approximately 4" x 7.25" (101.6 mm x 184.15mm)
- Standard pump is 12 plungers and Mini pump is 18.

Construction:

- Aluminum frame construction prevents any possible rust and allows easy cleaning and maintenance.
- The outside covers of the machine are completely made from stainless steel, designed according to the GMP/FDA requirements.
- Sealed construction to prevent leakage and subsequent contamination.
- Improved serviceability as most of the interior components slide out for easier access.
- Considerably reduced footprint and height.

Control Panel

- Control of all production and process parameters using Programmable Logic Controllers (PLC) with HMI interface.
- Electrical components and PLC located in a separate electrical panel.
- PC based visualization system (IPC with run-time software and industrial monitor).
- Left and right casting drums have independent control that could be adjusted on-the-fly (during production) by electronically changing the gear ratio between the drums and dies.
- CFR 21-part 11 software compliance.

User-Interface

- HMI Operator Interface - 19" multi-touch HMI widescreen, capacitive, high resolution (1920x1080), aluminium housing, and IP65 (waterproof).
- HMIs offer robust monitoring, control, status reporting and many other functions.

Mechanism

Medicine Pump System

- The medicine pump is independently driven by a servo motor and electronically synchronized with the die rolls.
- During a capsule size change, the operator inputs the number of die roll cavities using the touch screen.
- The medicine pump timing is done electronically.
- Precise injection timing adjustments are done electronically using the touch screen. The timing can also be adjusted during production (without stopping the machine). Since this timing can be adjusted with such high accuracy it improves on seal integrity of the capsule. This in turn increases capsule quality and productivity.
- The medicine pump is placed in a special housing which is completely separated from the medicine pump drive system. This allows quick change over and easy maintenance.

Commercial Scale Soft Gel Machine

SGM407NextGen[®]

Medicine Pump System

- The slide lubrication system for the pump is an electronic pump located inside the machine. It is separated from the medicine pump drive system (GMP construction), allowing no cross contamination of drive system with fill material.
- Standard pump is 12 plungers Mini pump is 18.

Die Roll Housing

- Two (2) independent die roll shafts driven by two (2) servo motors electronically synchronized, with high precision low backlash gearboxes.
- Fast and easy alignment of die roll shafts.
- No lubrication for die roll housing, leading to low maintenance cost.
- Safety guarding for die rolls, wedge, and mangle rolls.

Spreader Box

- Adaptable gelatin ribbon width allows minimum loss of ribbon net.
- Bronze construction.
- Gelatin level control is done electronically for gravity feeding.
- Ground level gelatin feeding also available.

Casting Drums

- "In-line" construction allows a straight gelatin ribbon transfer to the oil rolls and die rolls without any twisting.
- Cooling drums allow a high efficiency cooling at high speed.
- Water-and-air-cooling system integrated into machine. Chilled water required.

Ribbon Lubrication & Drive System

- Porous material for lubrication roller.
- Electronic metering pumps allow a very accurate ribbon lubrication.
- Easy and accurate oil quantity adjustment through HMI.
- Independent electrical drivers allow fine adjustments of the ribbon tension on each side.
- Easy access from the operator side to feed the ribbon on the oil rolls.

Die Roll Pressure System

- Electronic control of the pneumatic system.
- The Divider (Chute Assembly).
- Variable speed independent drive.
- Sealed construction.

Mangle Rolls

- Pneumatic cylinders for mangle roll pressure are used for ease of operation and maintenance.
- Electronic speed adjustment allows fine tuning of the ribbon tension and helps in the cutting process.

Commercial Scale Soft Gel Machine

SGM407NextGen®

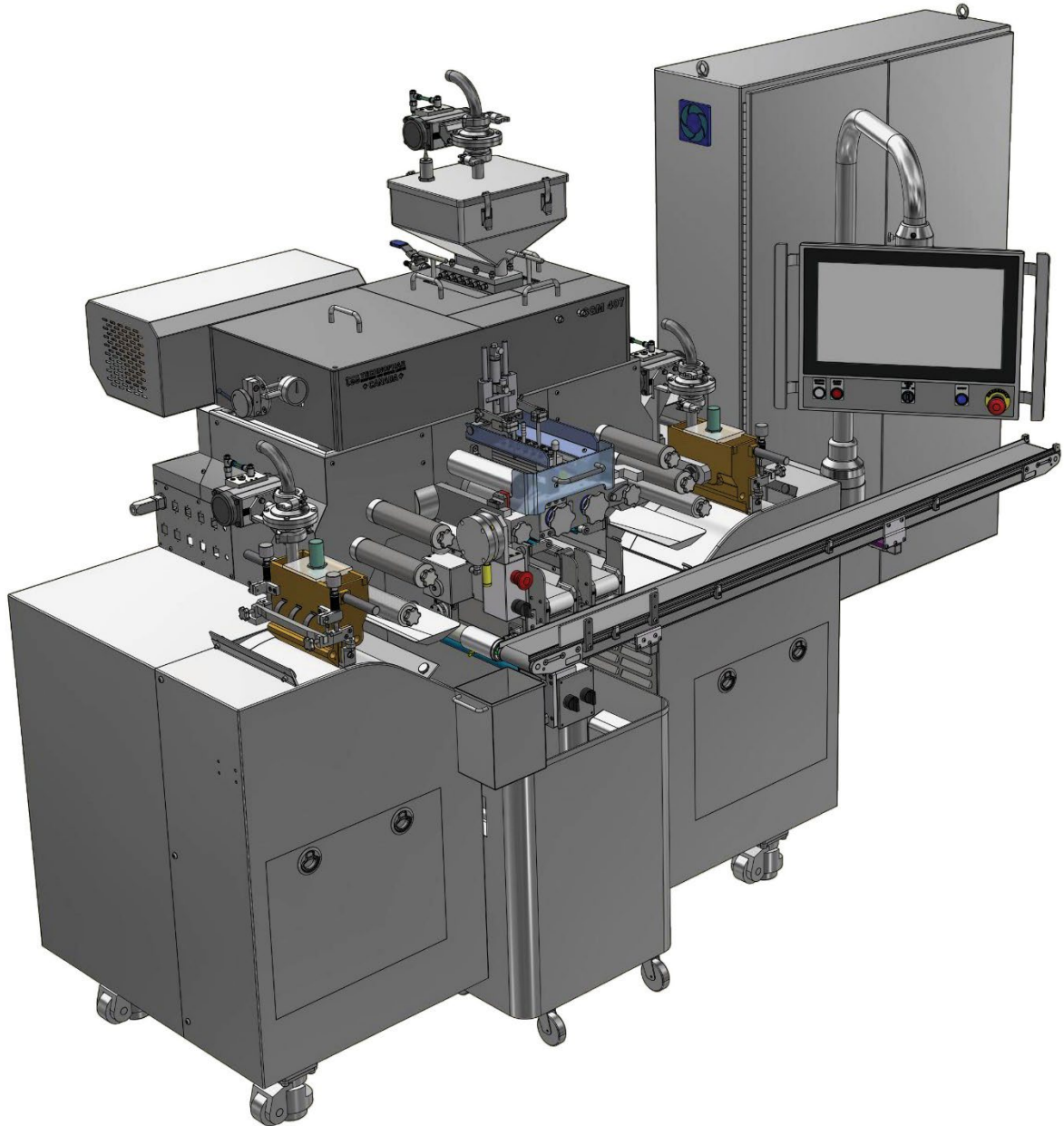

SOFT GELATINE ENCAPSULATION MACHINE SGM407NextGen

Commercial Scale Soft Gel Machine

SGM407NextGen®

Specifications

Soft Gelatin Encapsulation Machine

SGM407NextGen®

Units of Measure: mm / inches

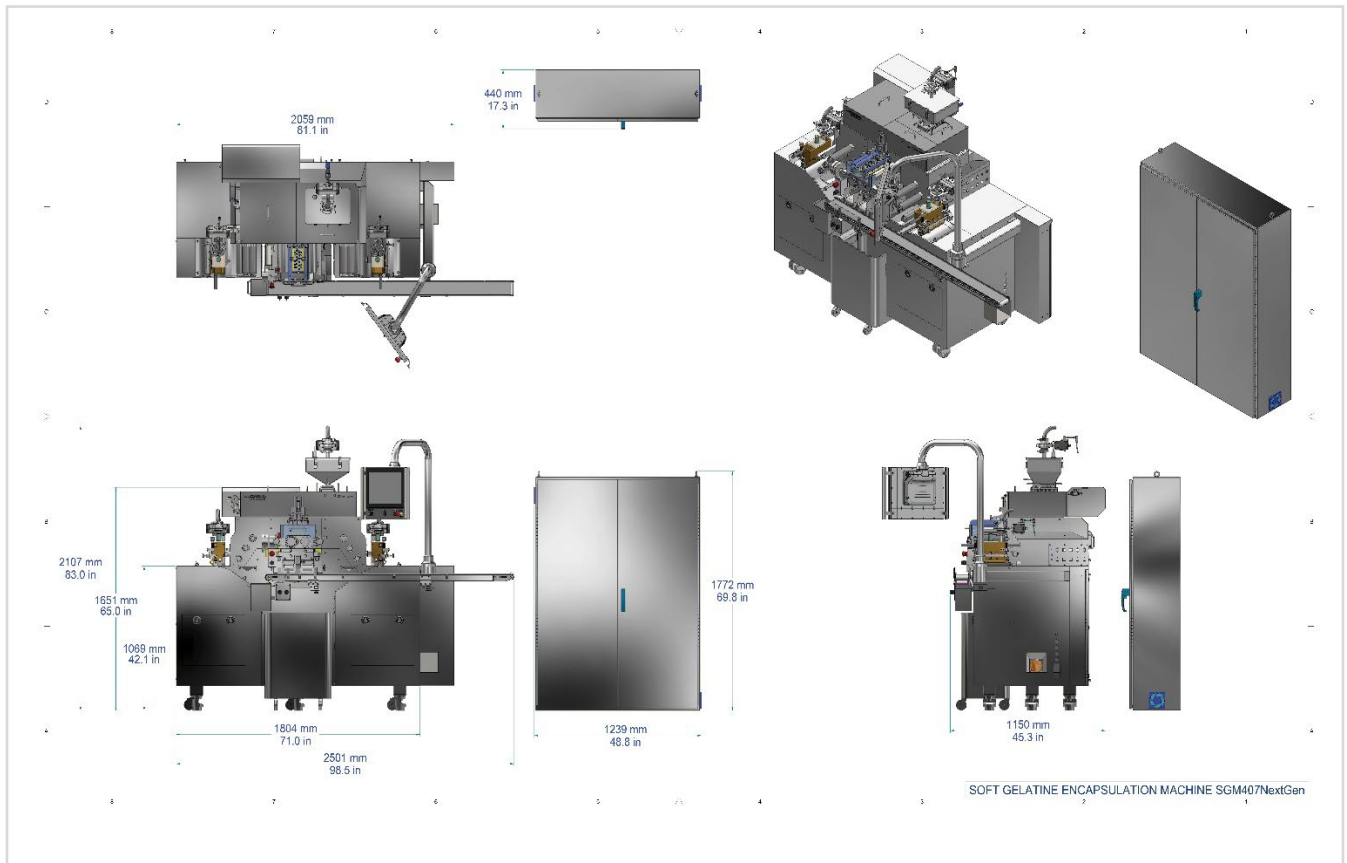

Commercial Scale Soft Gel Machine

SGM407NextGen®

Model No.	
SGM407NextGen®	Commercial Scale Soft Gel Capsule Machine
Specifications	
Soft Gel Machine Dimensions (mm/inches)	2501mmL x 1150mmW x 2107mmH (mm) / 98.5" L x 45.3" W x 83"H (inches)
Electrical Panel Dimensions (mm/inches)	1772mmH x 1239mmW / 69.8" H x 48.4" W
Die Roll Dimensions (mm/inches)	101.6 x 184.15L (mm) / 4 x 7.25L (inches)
Compressed Air	100 PSI
Chilled Water	6 GPM, 7°C
Weight (kg/lbs)	Approx. 2500kg/ 5512 lbs Machine

TECHNOPHAR

Technophar Global Headquarters

www.technophar.com

Copyright Technophar ©2022

2022-06-14 rev.